

ITR

Electronic fan speed controller



The ITR-9 series of electronic fan speed controllers regulate the speed of single-phase (110—240 VAC / 50—60 Hz) voltage controllable motors by varying the supplied voltage. The ITR-9 controllers provide automatic power supply detection. The minimum speed is adjusted via an internal trimmer. The output is regulated by a potentiometer in the range between the minimum output voltage and the supply voltage. The series features an unregulated output for connecting a valve, lamp, damper, etc. There are two start-up modes - kick start and soft start, selectable via a jumper.

Key features

- Wide power supply range (110—240 VAC / 50—60 Hz)
- Automatic supply voltage detection
- Adjustable stepless output voltage
- Minimum speed adjustable by internal trimmer
- Kick start or soft start
- Illuminated on/off switch

Technical specifications

Input voltage	110—240 VAC / 50—60 Hz	
Regulated output	U _{min} —U _s	
Maximum load	depends on the version	
Unregulated output	I _{max} 2 A	
Minimum output voltage, MIN	30—60 % of U _s	
Maximum output voltage, MAX	100 % U _s	
Kick start duration	8—10 s	
Ambient conditions	Temperature	-20—35 °C
	Relative humidity	5—95 % rH (non-condensing)
Protection standard	IP54 (according to EN 60529)	



Operational diagram

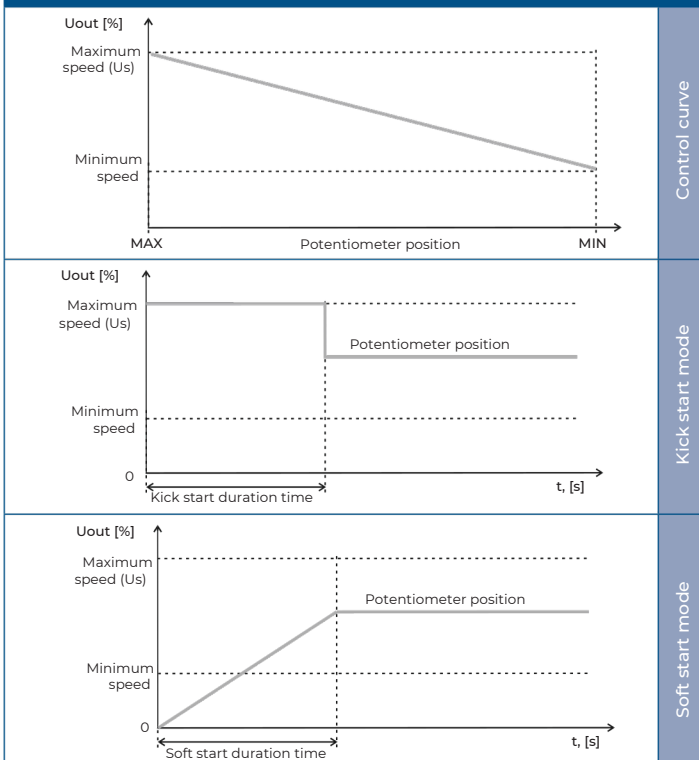

Area of use

- Fan speed control of voltage controllable motors in ventilation systems
- For indoor use only

Article codes

Article code	Rated max. current [A] 1,5	Fuse [A]
ITR-9-15-DT	3,0 5,0 6,0 10,0	(5*20 mm) F 3,15 A H 250 VAC
ITR-9-30-DT		(5*20 mm) F 5,0 A H 250 VAC
ITR-9-50-DT		(5*20 mm) F 8,0 A H 250 VAC
ITR-9-60-DT		(6,3*32 mm) F 10,0 A H 250 VAC
ITR-9100-DT		(6,3*32 mm) F 16,0 A H 250 VAC

Standards

- Low Voltage Directive 2014/35/EC
- Electromagnetic Compatibility (EMC) Directive 2014/30/EU
 - EN 61000-6-3:2007 + A1:2011 + AC:2012
 - EN 61000-6-2:2005 + AC:2005
 - EN 60730-1:2011
- WEEE 2012/19/EC
- RoHS Directive 2011/65/EC



ITR

Electronic fan speed controller



Legend

ITR-9-15-DT, ITR-9-30-DT

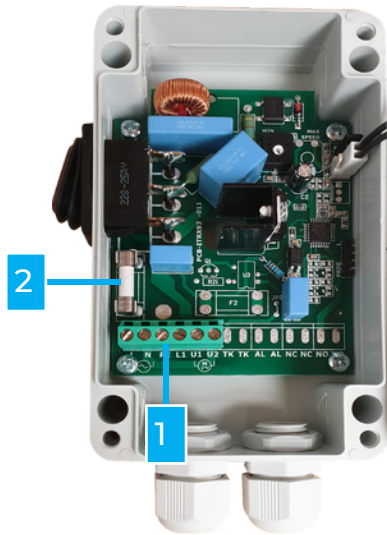

1 - Terminal block		
2 - Fuse		
3 - Kick start selection jumper		Kick start is enabled
		Soft start is enabled
4 - Minimum speed trimmer	Adjusts the min. speed (factory preset to 45 % of Us)	

* indicates closed position of the jumper.

Legend

ITR-9-50-DT

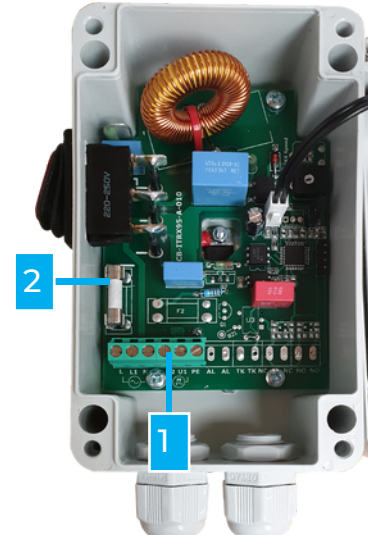

1 - Terminal block		
2 - Fuse		
3 - Kick start selection jumper		Kick start is enabled
		Soft start is enabled
4 - Minimum speed trimmer	Adjusts the min. speed (factory preset to 45 % of Us)	

* indicates closed position of the jumper.

ITR

Electronic fan speed controller

Legend

ITR-9-60-DT, ITR-9100-DT

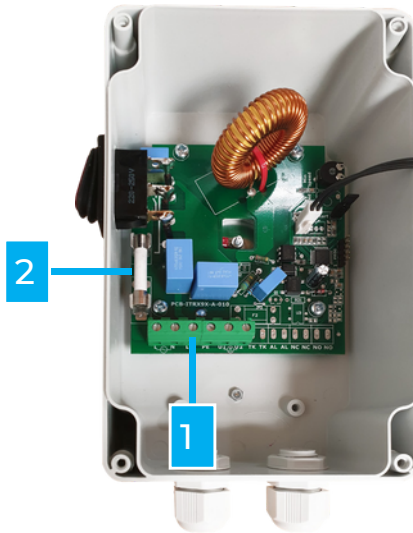

1 - Terminal block	<p>110—240 VAC / 230 VAC 50—60 Hz</p>
2 - Fuse	
3 - Kick start selection jumper	<p>Kick start is enabled</p> <p>Soft start is enabled</p>
4 - Minimum speed trimmer	<p>Adjusts the min. speed (factory preset to 45 % of U_s)</p>

* indicates closed position of the jumper.

Fixing and dimensions

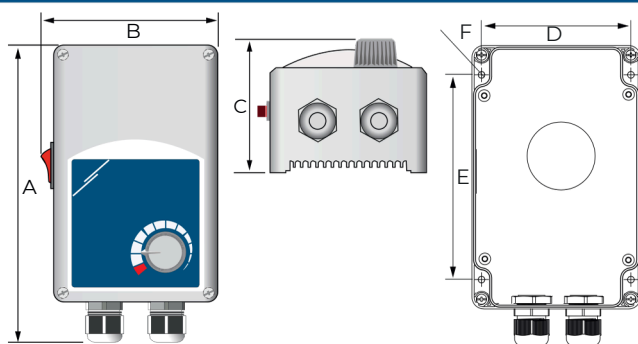

Article code	A	B	C	D	E	F
ITR-9-15-DT ITR-9-30-DT	162 mm	96 mm	75 mm	71 mm	108,8 mm	∅ 4,2
ITR-9-50-DT	162 mm	96 mm	93 mm	71 mm	108,8 mm	∅ 4,2
ITR-9-60-DT ITR-9100-DT	205 mm	124 mm	97 mm	102 mm	140 mm	∅ 4,6

Operational diagrams (only for versions with 1,5 and 3 A)

OFF position enabled: supply voltage connected to L and N

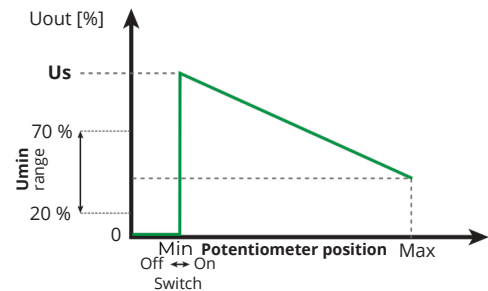

OFF position disabled: supply voltage connected to L1 and N

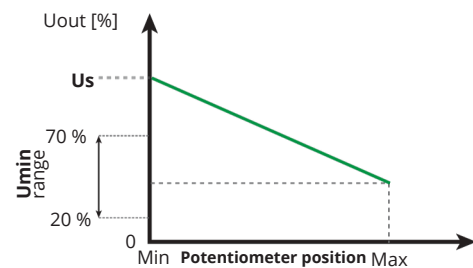

Note: To disable the OFF position, (1,5 A and 3,0 A version ONLY!) connect the 230 VAC supply voltage to the unregulated output (L1). In this case, do not connect the power supply to L.

Wiring and connections

ITR-9-15-DT, ITR-9-30-DT		
L	Power supply, line (110—240 VAC / 50—60 Hz)	
N	Neutral	
L1	Unregulated output, line (230 VAC / I_{max} 2 A)	
PE	Protective earth	
U2	Regulated output to motor, neutral	
U1	Regulated output to motor, line	
ITR-9-50-DT		
L	Power supply, line (110—240 VAC / 50—60 Hz)	
L1	Unregulated output, line (230 VAC / I_{max} 2 A)	
N	Neutral	
U2	Regulated output to motor, neutral	
U1	Regulated output to motor, line	
PE	Protective earth	
ITR-9-60-DT, ITR-9100-DT		
L	Power supply, line (110—240 VAC / 50—60 Hz)	
N	Neutral	
L1	Unregulated output, line (230 VAC / I_{max} 2 A)	
PE	Protective earth	
U2	Regulated output to motor, neutral	
U1	Regulated output to motor, line	
Connections	Cable cross section	max. 2,5 mm ²
	Cable gland clamping range	5—10 mm

ITR

Electronic fan speed controller



Packaging

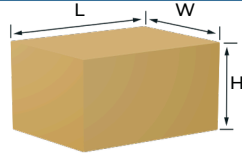

Article	Packaging	Length [mm]	Width [mm]	Height [mm]	Net weight	Gross weight
ITR-9-15-DT	Unit (1 pc.)	175	96	95	0,35 kg	0,41 kg
	Box (24 pcs.)	590	380	280	8,57 kg	10,97 kg
	Pallet (672 pcs.)	1,200	800	2,140	240,07 kg	323,78 kg
ITR-9-30-DT	Unit (1 pc.)	175	96	95	0,35 kg	0,41 kg
	Box (24 pcs.)	590	380	280	8,42 kg	10,81 kg
	Pallet (672 pcs.)	1,200	800	2,140	235,87 kg	319,25 kg
ITR-9-50-DT	Unit (1 pc.)	175	96	95	0,44 kg	0,50 kg
	Box (24 pcs.)	590	380	280	10,60 kg	13 kg
	Pallet (672 pcs.)	1,200	800	2,140	297,02 kg	366,40 kg
ITR-9-60-DT	Unit (1 pc.)	210	130	110	0,57 kg	0,67 kg
	Box (15 pcs.)	540	405	245	8,59 kg	11,06 kg
	Pallet (420 pcs.)	1,200	800	2,140	240,66 kg	326,22 kg
ITR-9100-DT	Unit (1 pc.)	210	130	110	0,72 kg	0,74 kg
	Box (15 pcs.)	540	405	245	10,80 kg	12,15 kg
	Pallet (420 pcs.)	1,200	800	2,140	302,40 kg	356,60 kg

Global trade item numbers (GTIN)

Packaging	Unit	Box	Pallet
ITR-9-15-DT	05401003008270	05401003501771	05401003700181
ITR-9-30-DT	05401003008287	05401003501788	05401003700198
ITR-9-50-DT	05401003008294	05401003501795	05401003700204
ITR-9-60-DT	05401003008300	05401003501801	05401003700211
ITR-9100-DT	05401003008317	05401003501818	05401003700228